

*TB 9-6625-2251-24

CALIBRATION PROCEDURE FOR OSCILLOSCOPE OS-291/G

Headquarters, Department of the Army, Washington, DC
21 December 2007

Distribution Statement A: Approved for public release; Distribution is unlimited.

REPORTING OF ERRORS AND RECOMMENDING IMPROVEMENTS

You can improve this manual. If you find any mistakes or if you know of a way to improve these procedures, please let us know. Mail your letter or DA Form 2028 (Recommended Changes to Publications and Blank Forms) directly to: Commander, U.S. Army Aviation and Missile Command, ATTN: AMSAM-MMC-MA-NP, Redstone Arsenal, AL 35898-5000. A reply will be furnished to you. You may also send in your comments electronically to our E-mail address: 2028@redstone.army.mil or by fax 256-842-6546/DSN 788-6546. For the World Wide Web use: <https://amcom2028.redstone.army.mil>. Instructions for sending an electronic 2028 can be found at the back of this manual.

SECTION		Paragraph	Page
I.	IDENTIFICATION AND DESCRIPTION		
	Test instrument identification	1	2
	Forms, records, and reports.....	2	2
	Calibration description	3	2
II.	EQUIPMENT REQUIREMENTS		
	Equipment required.....	4	2
	Accessories required.....	5	3
III.	CALIBRATION PROCESS		
	Preliminary instructions	6	3
	Equipment setup	7	3
	Channels 1 and 2 cursor accuracy	8	4
	Vertical gain accuracy.....	9	6
	Bandwidth accuracy.....	10	7
	Internal and external trigger sensitivity accuracy	11	9
	Horizontal linearity accuracy	12	11
IV.	ADJUSTMENTS		
	Calibration constants restoration	13	13
	Final procedure	14	16

*This bulletin supersedes TB 9-6625-2251-35, dated 27 September 2002, including all changes.

SECTION I IDENTIFICATION AND DESCRIPTION

1. Test Instrument Identification. This bulletin provides instructions for the calibration of Oscilloscope OS-291/G. Product description number CR-PD-0214-001 and TM 11-6625-3241-40 were used as the prime data sources in compiling these instructions. The equipment being calibrated will be referred to as the TI (test instrument) throughout this bulletin.

a. Model Variations. None.

b. Time and Technique. The time required for this calibration is approximately 5 hours, using the dc and low frequency technique.

2. Forms, Records, and Reports

a. Forms, records, and reports required for calibration personnel at all levels are prescribed by TB 750-25.

b. Adjustments to be reported are designated (R) at the end of the sentence in which they appear. When adjustments are in tables, the (R) follows the designated adjustment. Report only those adjustments made and designated with (R).

3. Calibration Description. TI parameters and performance specifications which pertain to this calibration are listed in table 1.

Table 1. Calibration Description

Test instrument parameters	Performance specifications
Bandwidth	Dc to 150 MHz
Delta time and cursors	Cursors: Vertical and horizontal $\pm 1\%$
Vertical	Vertical deflection: < 2 mV div to 5 V div 2%
Horizontal	Trigger sensitivity: Sweep at 0.5 div p-p vertical deflection dc to 50 MHz Internal: 1.5 div p-p vertical deflection at 150 MHz External: Sweep at ≤ 50 mV p-p vertical deflection dc to 50 MHz, increasing to ≤ 150 mV p-p vertical deflection at 150 MHz Linearity: 1 st and 11 th markers on 1 st and 11 th vertical graticule line, markers in between to $< \pm 0.1$ major division

SECTION II EQUIPMENT REQUIREMENTS

4. Equipment Required. Table 2 identifies the specific equipment to be used in this calibration procedure. This equipment is issued with Secondary Transfer Calibration Standards Sets AN/GSM-286, AN/GSM-287 or AN/GSM-705. Alternate items may be used by the calibrating activity. The items selected must be verified to perform satisfactorily prior to use and must bear evidence of current calibration. The equipment must meet or exceed the minimum use specifications listed in table 2. The accuracies listed in table 2

provide a four-to-one ratio between the standard and TI. Where the four-to-one ratio cannot be met, the actual accuracy of the equipment selected is shown in parenthesis.

5. Accessories Required. The accessories required for this calibration are common usage accessories issued as indicated in paragraph 4 above and are not listed in this calibration procedure.

Table 2. Minimum Specifications of Equipment Required

Common name	Minimum use specifications	Manufacturer model (part number)
CALIBRATOR	Voltage output: Range: 0.000200 to 20 V dc Accuracy: ±0.25%	Fluke, Model 5720A (5720A) (p/o MIS-35947)
OSCILLOSCOPE CALIBRATOR	Voltage output: Range: 10 mV to 5 V Accuracy: ±0.25% Time markers: 0.5 ns to 0.5 s Leveled sine wave: Range: 10 mV to 3 V p-p Frequency: 10 Hz to 150 MHz Accuracy: ±0.25%	Fluke, Model 5820A-5C-GHZ (5820A-5C-GHZ)

SECTION III CALIBRATION PROCESS

6. Preliminary Instructions

a. The instructions outlined in paragraphs 6 and 7 are preparatory to the calibration process. Personnel should become familiar with the entire bulletin before beginning the calibration.

b. Items of equipment used in this procedure are referenced within the text by common name as listed in table 2.

c. Unless otherwise specified, verify the result of each test and, whenever the test requirement is not met, take corrective action before continuing with the calibration. Adjustments required to calibrate the TI are included in this procedure. Additional maintenance information is contained in TM 11-6625-3241-40.

d. Unless otherwise specified, all control and control settings refer to the TI.

7. Equipment Setup

WARNING

HIGH VOLTAGE is used or exposed during the performance of this calibration. DEATH ON CONTACT may result if personnel fail to observe safety precautions. REDUCE OUPUT(S) to minimum after each step within the performance check where applicable.

- a. Ensure the **POWER-ON-OFF** pushbutton is in the **OFF** position (out).
- b. Connect TI to appropriate power source.
- c. Press **POWER-ON-OFF** pushbutton to **ON** (in) and allow 20 minutes for TI to warm-up and stabilize.
- d. Press **MENU OFF/EXTENDED FUNCTIONS** pushbutton once or twice.

NOTE

Two presses are necessary if any menu is presently displayed and one press if no menu is displayed.

NOTE

“Select” means to press appropriate front panel pushbutton to obtain a menu on crt. “Set” means to press appropriate menu pushbutton located on lower portion of crt bezel by underlining (turn on) or removing underline (turn off) desired menu selection.

- e. Set **CAL/DIAG**.
- f. Set **SELF CAL**.

NOTE

RUNNING will be displayed in lower right corner of crt screen for approximately 10 seconds. Upon successful completion of self calibration, **PASS** will be displayed above **SELF CAL** menu pushbutton.

- g. Press **MENU OFF/EXTENDED FUNCTIONS** pushbuttons.
- h. If TI displays **EXTENDED DIAGNOSTICS** menu, repeat **d** through **g** above. If TI displays **EXTENDED DIAGNOSTICS** menu again, corrective action must be taken before continuing procedure.
- i. Select **STORAGE ACQUIRE** pushbutton and verify **NORMAL** is on; if not, set **NORMAL** to on. Set **REPET ON: OFF** pushbutton to **ON**.

8. Channels 1 and 2 Cursor Accuracy

NOTE

If TI does not perform within limits specified in this paragraph, perform adjustments as indicated in **SECTION IV**.

- a. Select **TRIGGER MODE** and verify **AUTO** is on; if not, press Set **AUTO** to on.
- b. Rotate TI **CH 1 VOLTS/DIV** knob to set **CH1** for **2 mV** indication in upper left portion of crt. Select **CURSOR FUNCTION** and set **VOLTS** to on.
- c. Rotate **CURSOR DELAY** knob and align segmented cursor 3 divisions below crt horizontal centerline.

e. Select **CURSOR SELECT** and rotate **CURSOR DELAY** knob to align next segmented cursor 3 divisions above crt horizontal centerline. Display will indicate within Min/Max indications shown in table 3.

f. Repeat technique of **b** through **e** above using settings and indications listed in table 3.

Table 3. Channel 1 Cursor Volts Accuracy

Range VOLTS/DIV settings	Indications	
	Min	Max
2 mV	11.88 mV	12.12 mV
5 mV	29.7 mV	30.3 mV
10 mV	59.4 mV	60.6 mV
20 mV	118.8 mV	121.2 mV
50 mV	297 mV	303 mV
100 mV	594 mV	606 mV
200 mV	1.188 V	1.212 V
500 mV	2.970 V	3.030 V
1 V	5.94 V	6.06 V
2 V	11.88 V	12.12 V
5 V	29.7 V	30.3 V

g. Select **VERTICAL MODE**, set **CH 2** to on, and set **CH1** to off.

h. Repeat technique of **b** through **e** above for **CH 2**, using settings and indications in table 4 below.

Table 4. Channel 2 Cursor Volts Accuracy

Range VOLTS/DIV settings	Indications	
	Min	Max
2 mV	11.88 mV	12.12 mV
5 mV	29.7 mV	30.3 mV
10 mV	59.4 mV	60.6 mV
20 mV	118.8 mV	121.2 mV
50 mV	297 mV	303 mV
100 mV	594 mV	606 mV
200 mV	1.188 V	1.212 V
500 mV	2.970 V	3.030 V
1 V	5.94 V	6.06 V
2 V	11.88 V	12.12 V
5 V	29.7 V	30.3 V

i. Select **CURSOR FUNCTION** and set **Time** to on. Adjust **TI HORIZONTAL A AND B SEC/DIV** controls for **500 μs** indication on crt.

j. Rotate **CURSOR/DELAY** knob and align segmented movable cursor 3 divisions to left of center vertical line on crt.

k. Press **CURSOR SELECT** pushbutton and turn **CURSOR/DELAY** knob to align next segmented moveable cursor 3 divisions to right of center vertical line on crt. Display will indicate within Min/Max indications shown in table 5.

Table 5. Mode A Horizontal Test

HORIZONTAL SEC/DIV	Indications	
	Min	Max
500 μ s	2.9700 ms	3.0300 ms

l. Set **HORIZONTAL MODE** pushbutton to **B**. Display will indicate within Min/Max indications shown in table 6.

Table 6. Mode B Horizontal Test

HORIZONTAL SEC/DIV	Indications	
	Min	Max
500 μ s	2.9700 ms	3.0300 ms

- m. Select **VERTICAL MODE** pushbutton, set **CH 2** to off, and set **CH1** to on.
- n. Press **CURSOR FUNCTION** pushbutton and **Time** pushbutton to **OFF**.
- o. Select **HORIZONTAL MODE A**; **HORIZONTAL MODE B** will be turned off.

9. Vertical Gain Accuracy

NOTE

If TI does not perform as specified, perform adjustments as indicated in **SECTION IV**.

- a. Select **TRIGGER MODE** and verify **NORMAL** is set to on; if not, set **NORMAL** to on.
- b. Select **CH1 COUPLING/INVERT** and set **DC** to on and **50 Ω** to off.
- c. Connect oscilloscope calibrator **SOURCE/MEASURE CHAN 1** output to TI **CH 1** input connector, oscilloscope calibrator **SOURCE/MEASURE CHAN2** output to TI **CH 2** input connector. Rotate **CH 1 VOLTS/DIV** knob to set **CH 1** for 2 mV indication in upper left portion of crt.
- d. Rotate **HORIZONTAL A AND B SEC/DIV** knob for 500 μ s indication on crt.
- e. Set oscilloscope calibrator to a **VOLTAGE** output of 8 mV and frequency of 1 kHz.
- f. Rotate **TRIGGER LEVEL** knob as necessary to obtain a triggered display.
- g. Adjust oscilloscope calibrator knob located below the **EDIT FIELD** key for 4 divisions displayed on TI crt. The displayed **err** on oscilloscope calibrator will be within ± 2.0 percent.
- h. Repeat technique of e through g above for **CH1** with settings listed in table 7 below. The displayed **err** on oscilloscope calibrator will be within tolerance listed.

Table 7. Channel 1 Vertical Gain Accuracy

CH1 VOLTS/DIV settings	Oscilloscope calibrator	
	VOLTAGE settings	err display (%)
2 mV	8 mV	2.0
5 mV	20 mV	2.0
10 mV	40 mV	2.0
20 mV	80 mV	2.0
50 mV	200 mV	2.0
100 mV	400 mV	2.0
200 mV	800 mV	2.0
500 mV	2 V	2.0
1 V	4 V	2.0
2 V	8 V	2.0
5 V	20 V	2.0

i. Set oscilloscope calibrator to standby and select oscilloscope calibrator **CHAN 2**. Select **VERTICAL MODE**, set **CH 1** to off and set **CH 2** to on.

j. Repeat technique of **b**, and **e** through **g** above for **CH 2**, with settings in table 8 below.

Table 8. Channel 2 Vertical Gain Accuracy

CH2 VOLTS/DIV settings	Oscilloscope calibrator	
	VOLTAGE settings	err display (%)
2 mV	8 mV	2.0
5 mV	20 mV	2.0
10 mV	40 mV	2.0
20 mV	80 mV	2.0
50 mV	200 mV	2.0
100 mV	400 mV	2.0
200 mV	800 mV	2.0
500 mV	2 V	2.0
1 V	4 V	2.0
2 V	8 V	2.0
5 V	20 V	2.0

k. Select **VERTICAL MODE**, set **CH 1** to on and set **CH 2** to off.

l. Set oscilloscope calibrator output to standby.

10. Bandwidth Accuracy

NOTE

If TI does not perform as specified, perform adjustments as indicated in **SECTION IV**.

- a. Select **CH 1 COUPLING/INVERT** and set **50 Ohm** to on. Verify **DC** is set to on. Adjust **CH 1 POSITION** control and align cursor on extreme left of crt with center horizontal graticule line.
- b. Select **TRIGGER MODE** then set **AUTO**.
- c. Rotate **CH 1 VOLTS/DIV** knob to set **CH1** for a 5 mV indication on crt. Adjust **HORIZONTAL A AND B SEC/DIV** controls for 5 μ s indications on crt.
- d. Select oscilloscope calibrator **SOURCE/MEASURE CHAN 1** output.
- e. Set oscilloscope calibrator output for **LEVEL SINE**, with frequency at 50 kHz and amplitude for 6 divisions peak-to-peak signal on TI crt. Adjust **TRIGGER LEVEL** control as necessary to obtain a stable display.
- f. Adjust **LEVEL SINE** wave frequency until peak-to-peak signal on TI crt decreases to 4.2 divisions. Adjust **TRIGGER LEVEL** control and **HORIZONTAL A AND B SEC/DIV** controls as necessary to obtain a stable display. **LEVEL SINE** frequency will be 150 MHz or greater.
- g. Repeat technique of **e** and **f** above for settings listed in table 9 below. **LEVEL SINE** frequency will be within tolerance listed.

Table 9. Channel 1 Vertical Bandwidth Accuracy

Test instrument	Oscilloscope calibrator	
CH1 VOLTS/DIV settings	LEVEL SINE amplitude settings	LEVEL SINE frequency tolerance (\geq)
5 mV	30 mV	150 MHz
10 mV	60 mV	150 MHz
20 mV	120 mV	150 MHz
50 mV	300 mV	150 MHz
100 mV	600 mV	150 MHz
200 mV	1.2 V	150 MHz
500 mV	3 V	150 MHz

- h. Set oscilloscope calibrator to standby. Select **VERTICAL MODE**. Set **CH 1** to off and set **CH 2** to on. Select oscilloscope calibrator **CHAN 2** out.
- i. Repeat technique of **a** through **f** above for **CH 2** with settings listed in table 10 below. Leveled sine wave frequency will be within tolerance listed.

Table 10. Channel 2 Vertical Bandwidth Accuracy

Test instrument	Oscilloscope calibrator	
CH2 VOLTS/DIV settings	LEVEL SINE amplitude settings	LEVEL SINE frequency tolerance (\geq)
5 mV	30 mV	150 MHz
10 mV	60 mV	150 MHz
20 mV	120 mV	150 MHz
50 mV	300 mV	150 MHz
100 mV	600 mV	150 MHz
200 mV	1.2 V	150 MHz
500 mV	3 V	150 MHz

j. Set oscilloscope calibrator to standby. Select **VERTICAL MODE**, set **CH1** to on, and set **CH2** to off. Select **CH1 COUPLING/INVERT** and set **50 Ohm** to off. Verify **DC** is set to on.

k. Disconnect equipment setup.

11. Internal and External Trigger Sensitivity Accuracy

NOTE

If TI does not perform as specified, perform adjustments as indicated in **SECTION IV**.

a. Select oscilloscope calibrator **CHAN 1**, and connect oscilloscope calibrator **SOURCE/MEASURE CHAN 1** output through a 50 Ω feedthrough termination to a BNC dual input coupler. Connect one end of BNC dual input coupler to the TI **CH1** input and remaining end of BNC dual input coupler unconnected.

b. Rotate **CH 1 VOLTS/DIV** knob for 50 mV indications on crt display.

c. Set oscilloscope calibrator output for **LEVEL SINE** at amplitude and frequency listed in the first row of table 11.

d. Select **SETUP AUTO**.

NOTE

After auto setup sequence is completed, if necessary, adjust **CH 1 VOLTS/DIV** control for 50 mV indications on crt and **TRIGGER MODE** to **NORMAL**.

e. Adjust oscilloscope calibrator knob located below the **EDIT FIELD** key on the oscilloscope calibrator for 4 divisions peak-to-peak signal displayed on TI crt.

f. Rotate **CH 1 VOLTS/DIV** knob for 200 mV indications on crt. Rotate **TRIGGER LEVEL** control and verify TI will trigger.

g. Repeat technique of **b** through **f** above substituting frequencies in the next 2 rows of table 11.

h. Rotate **CH 1 VOLTS/DIV** knob for 50 mV indications on crt display.

i. Set oscilloscope calibrator output for **LEVEL SINE** amplitude and frequency listed in the last row of table 11. Rotate TI **TRIGGER LEVEL** knob as necessary until **TRIG'D** indicator illuminates.

j. Select **SETUP AUTO**.

NOTE

After auto setup sequence is completed, if necessary, rotate **CH 1 VOLTS/DIV** knob for 50 mV indications on CRT.

k. Select **STORAGE ACQUIRE** and set **REPET** to on. Adjust oscilloscope calibrator knob locate below the **EDIT FIELD** key for 6 divisions peak-to-peak signal displayed on TI crt.

l. Rotate **CH 1 VOLTS/DIV** knob for 200 mV indications on crt. Rotate **TRIGGER LEVEL** knob and verify TI will trigger.

Table 11. Internal Trigger Sensitivity

Oscilloscope calibrator	
LEVEL SINE amplitude	LEVEL SINE frequency
200 mV	50 KHz
200 mV	80 KHz
200 mV	50 MHz
300 mV	150 MHz

m. Select **TRIGGER SOURCE** and set **EXT** then set **SOURCE 1|2** to **1**. Connect unconnected end of BNC input coupler to **EXT TRIG 1**.

n. Set oscilloscope calibrator **LEVEL SINE** output for amplitude and frequency listed in the first row of table 12. Rotate **HORIZONTAL A AND B SEC/DIV** knob for an indication on crt as listed in the first row of table 12. Rotate **TRIGGER LEVEL** knob and verify TI will trigger.

o. Repeat technique of **n** above substituting frequencies, amplitude, and TI setting in the remaining rows of table 12.

Table 12. External Trigger 1 Sensitivity

Oscilloscope calibrator LEVEL SINE		Test instrument
Frequency	Amplitude	SEC/DIV settings
50 kHz	50 mV	5 μs
80 kHz	50 mV	5 μs
50 MHz	50 mV	5 ns
150 MHz	150 mV	5 ns

p. Move BNC dual input coupler connection from **EXT TRIG 1** to **EXT TRIG 2** and perform (1) through (3) below.

- (1) Select **TRIGGER SOURCE**.
- (2) Set **EXT**
- (3) Set **SOURCE 1|2** to **2**.

q. Repeat technique of **n** above using values in table 13.

r. Set oscilloscope calibrator to standby and disconnect equipment setup.

Table 13. External Trigger 2 Sensitivity

Oscilloscope calibrator LEVEL SINE		Test instrument	
		SEC/DIV settings	
Frequency	Amplitude		
50 kHz	50 mV	5 μs	
80 kHz	50 mV	5 μs	
50 MHz	50 mV	5 ns	
150 MHz	150 mV	5 ns	

- s. Select **SETUP AUTO**.

12. Horizontal Linearity Accuracy

NOTE

If TI does not perform as specified, perform adjustments as indicated in **SECTION IV**.

- a. Connect oscilloscope calibrator **SOURCE/MEASURE CHAN 1** output to **TI CH 1 INPUT**, and **SOURCE/MEASURE CHAN 2** output to **TI CH 2 INPUT**.
- b. Set oscilloscope calibrator for **MARKER** output listed in row one of table 14.
- c. Rotate **CH 1 VOLTS/DIV** knob for 500 mV indications on crt display and rotate **HORIZONTAL A AND B SEC/DIV** knob for **A and B SEC/DIV** settings listed in row one of table 14.
- d. Rotate **TRIGGER LEVEL** knob as necessary for triggered display.
- e. Rotate **HORIZONTAL A AND B POSITION** knob to align 1st marker with 1st graticule line. Adjust oscilloscope calibrator knob located under the **EDIT FIELD** key to align 11th marker with 11th graticule line. Markers will be within display tolerance listed in table 14 for the remaining vertical graticule lines between 1st and 11th vertical graticule lines.
- f. Repeat e above for remaining rows in table 14.

Table 14. MODE A Horizontal Linearity Accuracy

Oscilloscope calibrator		Test instrument		
MARKER output		A and B SEC/DIV setting		Display Tolerance (major divisions)
0.5	μs/div	500	ns/div	±0.1
1	μs/div	1	μs/div	±0.1
2	μs/div	2	μs/div	±0.1
5	μs/div	5	μs/div	±0.1
10	μs/div	10	μs/div	±0.1
20	μs/div	20	μs/div	±0.1
50	μs/div	50	μs/div	±0.1

Table 14. MODE A Horizontal Linearity Accuracy - Continued

Oscilloscope calibrator		Test instrument		
MARKER output		A and B SEC/DIV setting		Display Tolerance (major divisions)
0.1	ms/div	100	μs/div	±0.1
0.2	ms/div	200	μs/div	±0.1
0.5	ms/div	500	μs/div	±0.1
1	ms/div	1	ms/div	±0.1
2	ms/div	2	ms/div	±0.1
5	ms/div	5	ms/div	±0.1
10	ms/div	10	ms/div	±0.1
20	ms/div	20	ms/div	±0.1
50	ms/div	50	ms/div	±0.1
0.1	s/div ¹	100	ms/div	±0.1
0.2	s/div	200	ms/div	±0.1
0.5	s/div	500	ms/div	±0.1

¹Select **TRIGGER MODE** and set **NORMAL** to on.

g. Select **HORIZONTAL MODE B** and set **TRIGGER MODE** to **AUTO**.

h. Use technique of **b** through **f** above for settings listed in table 15.

Table 15. MODE B Horizontal Linearity Accuracy

Oscilloscope calibrator		Test instrument		
MARKER output		A AND B SEC/DIV setting		Display tolerance (major divisions)
0.5	μs/div	500	ns/div	±0.1
1	μs/div	1	μs/div	±0.1
2	μs/div	2	μs/div	±0.1
5	μs/div	5	μs/div	±0.1
10	μs/div	10	μs/div	±0.1
20	μs/div	20	μs/div	±0.1
50	μs/div	50	μs/div	±0.1
0.1	ms/div	100	μs/div	±0.1
0.2	ms/div	200	μs/div	±0.1
0.5	ms/div	500	μs/div	±0.1
1	ms/div	1	ms/div	±0.1
2	ms/div	2	ms/div	±0.1
5	ms/div	5	ms/div	±0.1
10	ms/div	10	ms/div	±0.1
20	ms/div	20	ms/div	±0.1
50	ms/div	50	ms/div	±0.1
0.1	s/div ¹	100	ms/div	±0.1
0.2	s/div	200	ms/div	±0.1
0.5	s/div	500	ms/div	±0.1

¹Select **TRIGGER MODE** and set **NORMAL** to on

- i. Set oscilloscope calibrator to standby and disconnect equipment setup.

SECTION IV ADJUSTMENTS

13. Calibration Constants Restoration

WARNING

HIGH VOLTAGE is used or exposed during the performance of this calibration. DEATH ON CONTACT may result if personnel fail to observe safety precautions. REDUCE OUTPUT(S) to minimum after each step within the performance check where applicable.

- a. Press **POWER-ON-OFF** pushbutton to **OFF** (out) and remove the cabinet from test instrument. Remove jumper J156 (fig. 1) from P156 on side board (located on right side of instrument near rear).

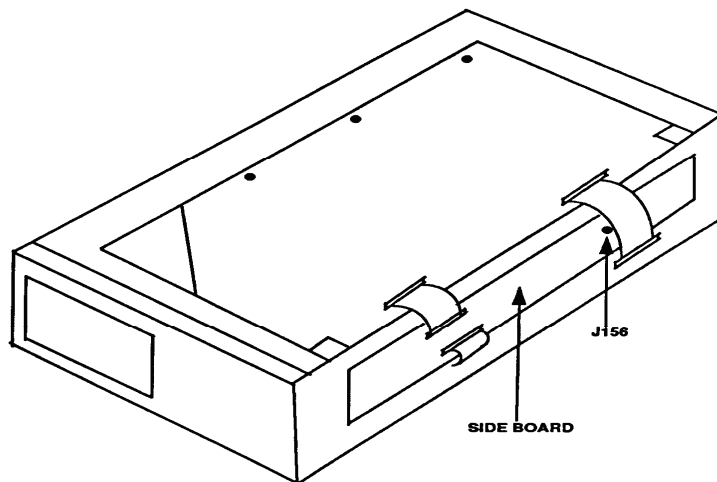

Figure 1. Test instrument jumper location (cabinet removed).

CAUTION

Operation of TI with the cabinet removed may cause damage to electrical components in the test instrument.

- b. Replace cabinet on TI.
- c. Connect TI to ac power source.

NOTE

When **POWER-ON-OFF** pushbutton is pressed to **ON** (in), a set of power-up tests are performed for several seconds. Upon successful completion of power-up tests, TI will enter **ACQUIRE** or **SAVE** mode, depending on mode in effect when power was removed, and be ready for operation. If an error is encountered during power-up tests, an "Extended Diagnostics" menu is displayed indicating corrective action is needed before proceeding with this procedure. Once power is on, this procedure must be completed without pressing TI **POWER-ON-OFF** switch to **OFF** (out).

d. Press **POWER-ON-OFF** pushbutton to **ON** (in), and allow 20 minutes for equipment to warm-up and stabilize.

NOTE

Throughout this procedure, pressing certain pushbuttons will cause various options to be displayed on lower portion of TI crt.

e. Press and release **MENU OFF/EXTENDED FUNCTIONS** pushbutton to display **EXT FUNCT** options on crt. If options are not displayed, press and release the same pushbutton a second time to display options.

NOTE

Pressing pushbuttons directly under options displayed on crt will set (underline) turn on or (remove underline) turn off options.

f. Set **CAL/DIAG** and set **SELF DIAG**.

NOTE

Message **RUNNING** will appear on crt. Upon successful completion of self diagnostics cycle, message **RUNNING** will be replaced by message **PASS** above **SELF DIAG** option. Crt will be blank for 15 to 20 seconds.

g. Press and release **MENU OFF/EXTENDED FUNCTIONS** pushbutton.

h. Press and release **MENU OFF/EXTENDED FUNCTIONS** pushbutton two times to display **EXT FUNCT** options on crt.

i. Set **CAL/DIAG** option on crt.

NOTE

Crt may display a **PASS** indication for **SELF CAL** option. Step **o** below should still be performed to update stored information and prepare test instrument to respond to further testing.

- j. Set **SELF CAL**. Crt will display message **RUNNING**. After 10 to 15 seconds message will be replaced by **PASS** directly above **SELF CAL** option.
- k. Press and release **MENU OFF/EXTENDED FUNCTION** pushbutton two times to display **EXT FUNCT** options on crt.
- l. Set **CAL/DIAG** to display options on crt.
- m. Set **EXT CAL** to display options on crt.
- n. Set **ATTEN** and perform (1) through (8) below to establish attenuator gain **DAC** voltage reference levels.
 - (1) Crt will display message **CONNECT CH 1 TO 0.2 VDC**.
 - (2) Set calibrator (Fluke, Model 5720A) to 0 V output and connect to **TI CH 1** input.
 - (3) Set calibrator (Fluke, Model 5720A) for 0.200 V output.
 - (4) Set **ATTEN**. Crt will display message **RUNNING**. After approximately 3 to 5 seconds message will change to **CONNECT CH 1 to 2.0 VDC**.
 - (5) Set calibrator (Fluke, Model 5720A) for 2.00 V output and set **ATTEN**. Crt will display message **RUNNING**. After approximately 3 to 5 seconds message will change to **CONNECT CH 1 TO 20 VDC**.
 - (6) Set calibrator (Fluke, Model 5720A) for 20 V and set **ATTEN**. Crt will display message **RUNNING**. After approximately 3 to 5 seconds message will change to **CONNECT CH 2 TO 0.2 VDC**.
 - (7) Set calibrator (Fluke, Model 5720A) for 0 V output and to standby mode and move connection on TI from **CH 1** input connector to **CH 2** input connector.
 - (8) Repeat technique of (3) through (6) above for **CH 2**, changing calibrator (Fluke, Model 5720A) to appropriate settings.

NOTE

After successful completion of above sequence, crt will display **PASS** message above option **ATTEN**. If a **FAIL** message is displayed, verify test setup and repeat **n** (1) through (8) above. If **FAIL** message is still displayed, corrective action is necessary.

- (9) Crt will display message **PASS** above option **ATTN**. Disconnect test setup.
- o. Perform (1) through (6) below to establish trigger circuit DAC voltage reference level.
 - (1) Set **TRIGGER**. Crt will display message **CONNECT TRIGS TO GND**.
 - (2) Set calibrator (Fluke, Model 5720A) for 0 V output and connect to **TI EXT TRIG 1** and **EXT TRIG 2** through dual input coupler.
 - (3) Set calibrator (Fluke, Model 5720A) for 0.000200 V output. Set **TRIGGER**. Crt will display message **RUNNING**. After approximately 3 to 5 seconds crt will display message **CONNECT...TO 0.5 V**.

(4) Set calibrator (Fluke, Model 5720A) for 0.500 V and set **TRIGGER**. Crt will display message **RUNNING**. After approximately 3 to 5 seconds crt will display message **CONNECT...TO 2.0 V**.

(5) Set calibrator (Fluke, Model 5720A) for 2.00 V and set **TRIGGER**. Crt will display message **RUNNING**.

NOTE

After successful completion of above sequence, crt will display **PASS** message above option **TRIGGER**. If a **FAIL** is displayed, verify test setup and repeat (1) through (5) above. If **FAIL** message is still displayed, corrective action is necessary.

(6) Crt will display message **PASS** and above option **TRIGGER**. Disconnect test setup.

p. Perform (1) through (4) below for Ramp (REPET).

NOTE

REPET calibration adjusts timing of jitter correction amplifiers so that waveform samples are correctly placed with respect to trigger point in repetitive acquisition mode.

(1) Press **MENU OFF/EXTENDED FUNCTIONS** pushbutton two times.

(2) Set **CAL/DIAG**.

(3) Set **EXT CAL** to display **EXT CAL** menu.

(4) Set **REPET**. Crt will display **RUNNING** and then display **PASS** or **FAIL**. If **PASS** is displayed calibration is complete; if display changes to **FAIL**, corrective action is needed.

NOTE

With jumper J156 (fig. 1) removed, calibration constants stored in TI firmware will be lost when power is applied and must be reestablished by performing this procedure completely.

q. Perform (1) through (3) below to prevent calibration constants from being lost.

(1) Press **TI POWER-ON-OFF** switch to **OFF** (out) and remove cabinet from TI.

(2) Replace jumper (J156) (fig. 1) on P156 on side board (located on right side of instrument near rear panel).

(3) Replace cabinet on TI.

14. Final Procedure

a. Deenergize and disconnect all equipment.

b. Annotate and affix DA label/form in accordance with TB 750-25.

By Order of the Secretary of the Army:

Official:



JOYCE E. MORROW
*Administrative Assistant to the
Secretary of the Army*

0729611

GEORGE W. CASEY, JR.
*General, United States Army
Chief of Staff*

Distribution:

To be distributed in accordance with the initial distribution number (IDN) 344399, requirements for calibration procedure TB 9-6625-2251-24..

Instructions for Submitting an Electronic 2028

The following format must be used if submitting an electronic 2028. The subject line must be exactly the same and all fields must be included; however, only the following fields are mandatory: 1, 3, 4, 5, 6, 7, 8, 9, 10, 13, 15, 16, 17, and 27.

From: "Whomever" whomever@redstone.army.mil
To: <2028@redstone.army.mil

Subject: DA Form 2028

1. **From:** Joe Smith
2. **Unit:** home
3. **Address:** 4300 Park
4. **City:** Hometown
5. **St:** MO
6. **Zip:** 77777
7. **Date Sent:** 19-OCT-93
8. **Pub no:** 55-2840-229-23
9. **Pub Title:** TM
10. **Publication Date:** 04-JUL-85
11. **Change Number:** 7
12. **Submitter Rank:** MSG
13. **Submitter FName:** Joe
14. **Submitter MName:** T
15. **Submitter LName:** Smith
16. **Submitter Phone:** 123-123-1234
17. **Problem:** 1
18. **Page:** 2
19. **Paragraph:** 3
20. **Line:** 4
21. **NSN:** 5
22. **Reference:** 6
23. **Figure:** 7
24. **Table:** 8
25. **Item:** 9
26. **Total:** 123
27. **Text**

This is the text for the problem below line 27.

